



# **DELTA**

## **Straight Inclined Platform Lift**



# **OWNER'S MANUAL**

(To Be Retained by Owner After Installation by Authorized Savaria Dealer)

Part No. 000820  
15-m07-2020

---

---

## IMPORTANT - READ FIRST

Ensure that only an authorized Savaria mechanic installs and services your Lift. Under no circumstances is anyone other than a mechanic with Savaria training and authorization to install, adjust, service or modify any mechanical or electrical device on this equipment.

Failure to follow this warning can result in safety system compromises or defeat; this can result in serious injury or death. Savaria accepts no liability for property damage, warranty claims or personal injury, including death, in this circumstance.

Passenger safety is the result of countless details in the equipment design, manufacture, and installation. After installation, reliable operation and continual safe operation requires regular inspection and maintenance as outlined in this manual, or more frequently where usage, environment, or local jurisdiction requires. As the Owner, you are responsible for ensuring that regular inspections and maintenance occur in a timely manner as per the manufacturer's recommendations and maintenance schedule.

Refer to this owner's manual for unit description, setup, operating instructions, and a maintenance schedule for your Lift. Upon completion of installation, the Savaria mechanic must provide you with the information for the box below and ensure it is recorded in this owner's manual. In addition, either you or the Savaria mechanic must keep any service and/or maintenance records in the Maintenance Record section of this owner's manual.

At all times, your Lift must be maintained in compliance with the applicable standard to which it has been built and installed.

- United States - A18.1 – Safety Standard for Platform Lifts and Stairway Chairlift
- Canada - CSA B355/613 – Platform lifts and stair lifts for barrier-free access
- Europe - EN-81-40 – Stairlifts and inclined lifting platform intended for persons with impaired mobility
- Europe - 2006/42/EC – Machinery Directive

Depending on your country or region, the local authority code variant may apply.

To ensure safe operation of your Lift, pay careful attention to the important notes, and follow the instructions and any additional safety regulations in this manual.

### FOR OWNER'S RECORDS

Customer Name: \_\_\_\_\_

Installing Dealer: \_\_\_\_\_

Dealer's Telephone Number: \_\_\_\_\_

Date Installed: \_\_\_\_\_

Serial/Job Number: \_\_\_\_\_

---

## WARRANTY

Ensure your Savaria Dealer provides you with a copy of the manufacturer's limited parts warranty and documentation relating to any Dealer labour warranty.

---

## CONTENTS

TO ENSURE SAFE OPERATION .....	4
1. DESCRIPTION .....	5
Lift Unit .....	5
Guide Rails .....	8
Battery Charging .....	8
Safety Features .....	9
2. SPECIFICATIONS .....	10
3. PROPER AND IMPROPER USE .....	11
Proper Use .....	11
Improper Use .....	11
4. OPERATION .....	12
Warnings .....	12
Operation .....	13
Manual Operation in an Emergency .....	16
5. TROUBLESHOOTING .....	19
Diagnostic LEDs .....	20
6. MAINTENANCE .....	21
Maintenance Record .....	23

---

## TO ENSURE SAFE OPERATION

To ensure safe operation of this unit, pay careful attention to the important notes below.



### WARNING

**This symbol accompanies essential safety instructions. Follow these instructions and any additional safety regulations.**

- Read this manual carefully before using the platform lift.
- To prevent accidents, adhere strictly to the instructions and keep clear of moving parts at all times.
- Never exceed the maximum load capacity as indicated on the side of the carriage.
- Passengers must remain in the wheelchair or seated while the lift is operating.
- Follow instructions on all equipment labels at all times. Replace any damaged labels immediately.
- Ensure that only qualified personnel perform maintenance and service on the unit.
- When replacing parts, be sure that only genuine Savaria parts are used.
- This unit is intended for use by a mature person who understands its proper operation as set out in this manual.



### WARNING

**At no time should children under the age of 16 use the lift while unsupervised.**

- Prior to operation, make sure that:
  - All areas in and around the lift are clear of any obstructions.
  - All lights are functioning properly.
- Test your keys and emergency stop button every month.



### WARNING

**Wheelchair users must ALWAYS ride facing in the direction of travel. Users without a wheelchair must ride sitting down on the seat and wearing the safety belt.**

# 1. DESCRIPTION

## Lift Unit

The lift unit is comprised of the components shown in Figure 1 below.

- Platform control panel which has a key switch, an emergency STOP button, an alarm button and a running light (see Figure 4 on page 7) to indicate that the unit is in use
- Safety arms
- Pendant control
- Carriage (behind cover)
- Platform access ramps
- Main power switch

**Figure 1**

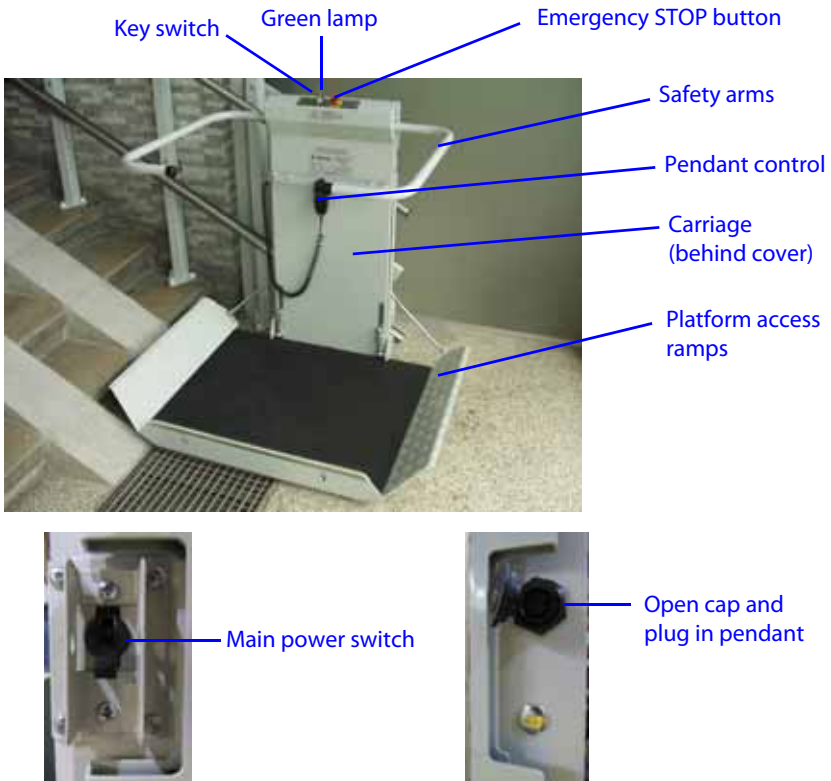

The drive unit (shown in Figure 2 below) has the following components:

- Gear box
- Motor
- Handwheel
- Brake release lever

Note that the lower guide rail shown in Figure 2 is not part of the drive unit; it is shown for reference only.

**Figure 2**

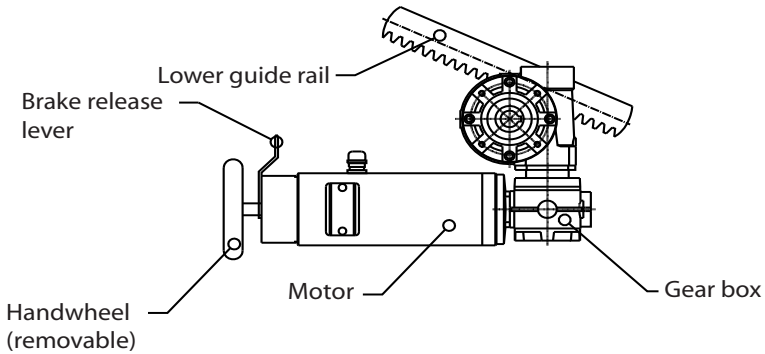

The pendant control (shown in Figure 3 below) has **UP** and **DOWN** arrow buttons to move the lift up and down the stairway, an alarm button and a red emergency STOP button to stop the lift in an emergency. When not in use, hang the pendant control on the safety arm using the hook at the back of the control.

**Figure 3**



## Control Buttons

The control buttons on the pendant and the call/send stations are constant-pressure type. This means you must press and hold the button to operate it. Release the button to stop the function. The emergency STOP button is push/pull.

Note that you need a key to activate the controls on the platform control panel and at the landing call station (if the call station is equipped with a key switch).



### WARNING

**Never use the lift if the control buttons do not work in constant-pressure mode.**

The landing call/send station controls are powered by a 9-volt battery. Under normal operation the green light on the call station will flash when the key switch is turned on and a control button is pressed. If the green light does not flash, this indicates that it's time to change the battery.

### Emergency STOP Button

When you press the red emergency STOP button on the platform control panel (shown in Figure 4), the lift will stop immediately. To release the emergency STOP button, press and turn it slightly clockwise.

### Running Light

The red running light flashes to indicate that the unit is in use.

*Figure 4*

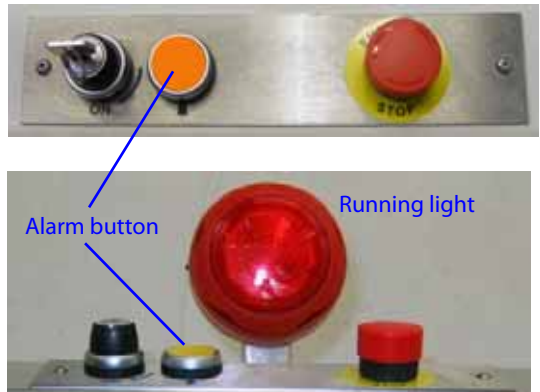

### WARNING

**Check the emergency STOP button operation weekly. If the lift does not stop when the button is pressed, DO NOT use the lift. Contact your authorized dealer.**

## Guide Rails

The platform lift travels up and down the stairway along two guide rails – an upper rail and a lower rail. A sample installation layout is shown in Figure 5.

**Figure 5**

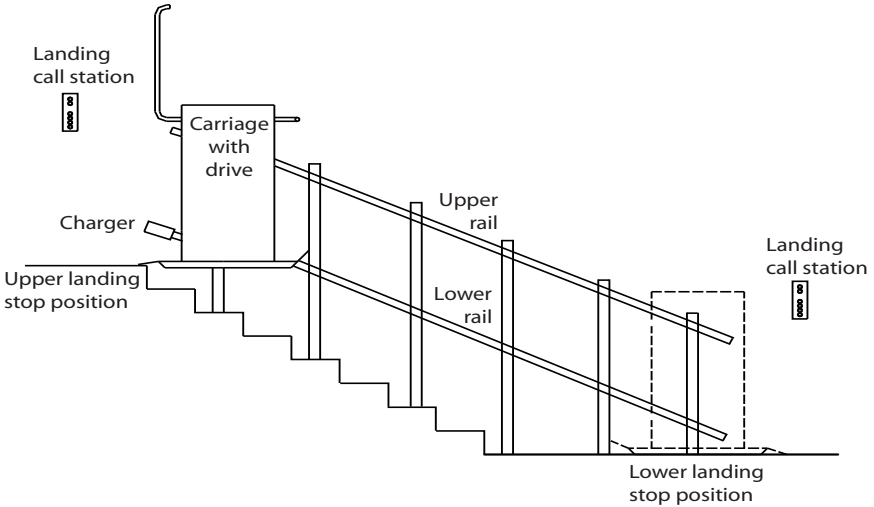

## Battery Charging

The lift motor is powered by batteries that are charged at the upper and lower landing stop positions. When you are not using the lift, be sure to park it at one of the stop positions. If the lift is not parked at a stop position, a warning beeper will sound.

If the lift is not parked at a stop position after 5 minutes of use, then the beeper will sound every second. Move the lift to a stop position to charge the batteries.

If the lift is parked at a stop position and the beeper still sounds, the lift is not charging. Turn off the main power switch of the lift and check for any power outages in the building or for blown fuses. If the beeper continues to sound after checking these items, contact your authorized dealer.

If the battery charge is too weak for normal operation, the beeper will sound every 2.5 seconds. Move the lift to a stop position to charge the batteries. If the beeper continues to sound after charging, contact your authorized dealer. In the case of weak batteries, the control system is programmed so the lift is always able to reach the lower stop position with the remaining battery charge.



---

## Safety Features

### Safety Arms and Platform Ramps

While in motion, the platform is protected by two safety arms. The platform is also protected by two ramps which have the dual function of facilitating access to the lift at the landings and of retaining the wheelchair while the lift is in motion. Before the lift leaves the floor, the safety arms must be down and the platform access ramps must be up. If the safety arms or platform ramps encounter an obstacle as they move into position, a microswitch is tripped, preventing operation of the lift until the obstacle is removed.

### Obstruction Sensors

During travel, the edges of the platform ramp and carriage are protected by sensors which stop the lift if it touches any obstacle. There are also safety underpan sensors to detect any obstacle underneath the platform and carriage and stop the lift.

### Safety Brake (Overspeed)

The lift is equipped with a mechanical safety brake. It engages if a drive component fails or if the normal downward travel speed is exceeded by a preset amount. Application of the brake slows the lift to a stop.



#### **WARNING**

**When the safety brake engages, the lift remains locked out of use. Contact your authorized dealer to release the brake and return the lift to normal operation.**

### Limit Switches

The upper and lower limit switches allow the lift to stop automatically in the correct position at the upper or lower end of the staircase. If the upper or lower limit switch fails, the final safety limit switch stops the unit.



#### **WARNING**

**If the lift is unable to move after it stops, contact your authorized dealer to return the lift to normal operation.**

### Audio Visual Alarm

There is an audio visual alarm to indicate that the unit is running. This includes a buzzer and a red running light on the platform control panel that flashes when the unit is in use. See Figure 4 on page 7.

## 2. SPECIFICATIONS

<b>Performance</b>	
Travel direction	Forward/backward
Travel length	Up to 82 feet (25 metres)
Speed (up/down)	20 feet/minute (0.1 metres/second)
Daily cycle	Normal: 10 Heavy: 20 Excessive: 30 Maximum starts in 1 hour on standard installation: 5
Capacity	1 person in wheelchair or sitting on the optional manual folding seat; seat capacity is 330 lb (150 kg)
Maximum load	550 lb (250 kg); 660 lb (300 kg) optional Refer to the data label on the unit
Gradient	Constant, 15° to 45°
Duty cycle	3 minutes on/7 minutes off
<b>Environmental Conditions</b>	
Temperature	32°F to 104 °F (0 °C to 40 °C)
Humidity	Maximum 70%
Noise	Less than 70 db
Power supply	24V DC (battery system); 120VAC for charger
Motor	0.66 hp (0.5 kW)
<b>Controls</b>	
Pendant control buttons	Two drive buttons used to move the lift up or down the stairway and one emergency STOP button
Call station controls	Used to call/send the lift, fold/unfold the platform (for optional automatic platform); has an optional key switch to enable controls
Platform control panel	Emergency STOP button to bring the lift to an immediate stop Key switch to enable controls Alarm button to signal for help Running light that flashes to indicate the unit is in use
Options	Savaria Link remote monitoring

---

## 3. PROPER AND IMPROPER USE

### Proper Use

The DELTA lift is an accessibility device used to provide access over straight-run stairs with a constant gradient. The lift will transport a passenger either sitting in a wheelchair or on the optional manual folding seat. The lift is designed for use by a self-sufficient person with knowledge of the unit's operation and general maintenance instructions.

#### NOTE

*If the person using the lift is not self-sufficient, it must be operated by an attendant.*

*Always remain still while the lift is in motion.*

*Do not use the lift when someone else is using the stairway.*

### Improper Use

- Do not transport objects on the platform.
- Do not transport more than one person at a time.
- Do not stand on the platform.
- Do not overload the lift.
- Do not spray any liquids onto the lift or rails.
- Do not make any modifications to the lift.



#### WARNING

**For your safety, use the lift only as intended and read this manual before using the lift.**

## 4. OPERATION

### IMPORTANT

Prior to operating the lift, a manual wheelchair **MUST** have the wheels locked and any power-operated device **MUST** have the power turned off. If using the provided fold-down seat, ensure that the seat belt is securely fastened.

### NOTE

*Position the wheelchair, scooter or walker **CENTRAL** on the platform.*



### WARNING

**DO NOT drive against the fold-up ramp.**

### Warnings

- Ensure there is unrestricted access to the platform and main power switch.
- Never overload the platform.
- While on board the lift, always remain seated with the wheelchair brakes on. If the wheelchair is electric, turn it off as long as the lift is moving. Keep your feet on the wheelchair footrest.
- Note that in some installations where there is low overhead, you may have to reposition yourself on the platform to avoid contacting the ceiling.
- If using the optional manual folding seat, make sure the seat belt is securely fastened. Be sure to fold up the seat after use.
- While on board the lift, always look in the direction of travel and stop the lift immediately if there is anyone on the travel route.
- During operation of the lift, the landings and travel route must always be illuminated.
- Keep the platform key in a safe storage place for access by authorized personnel only. Be sure to remove the key after each use.
- Never leave the lift halfway up the staircase.
- Never use the lift unless a trained person is available to operate it in manual mode in an emergency situation.
- Never place your hands or any objects close to the rails or the platform while the lift is in motion.

## Operation

- 1 Make sure the pendant control is plugged into the jack on the left side wall of the carriage body (see Figure 6). If not, open the cap and plug in the pendant.
- 2 Turn on the main power switch located on the right side wall of the carriage body (see Figure 6). Note that when the main power switch is turned off, you cannot run the lift using any of the controls.

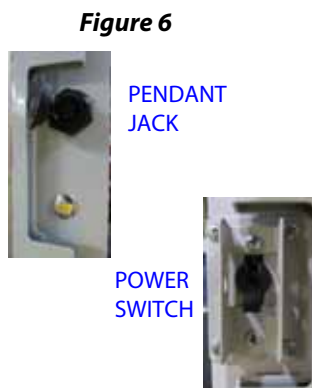

- 3 If the lift is not at the desired landing, you can call the lift using the call station controls (Figure 7 shows a call station for an optional automatic platform). Note that the call station controls will only control the lift when the platform is folded up.

- 4 To call the lift, first insert the key into the call station key switch (if equipped) and turn it on. The green light on the call station will turn on.
- 5 Press and hold either the **UP** or **DOWN** button to move the lift towards you. The green light on the call station will flash while the lift is moving.



**NOTE:** Make sure you can see the lift at all times when it is moving; stop it immediately if there is an obstacle in the way.

- 6 The lift will stop automatically at the desired landing.  
In the event that the lift does not stop after releasing the control button, you can turn off the call station key switch (if equipped) to stop travel.
- 7 For lifts with a manual platform, lower the platform by hand. The safety arm will rise up and the access ramp will lower automatically. Be careful of the moving parts.

For lifts with an optional automatic platform, press and hold the **UNFOLD** button on the call station to lower the platform and raise the safety arm. The access ramp will lower automatically.

- 8 If the optional manual folding seat is to be used, fold down the seat.
- 9 Turn off and remove the key from the call station key switch (if equipped).
- 10 Drive the wheelchair onto the platform (Figure 8 - top) and park it so that no part of the passenger's body or the wheelchair projects from the platform. Engage the wheelchair brakes. If the wheelchair is electric, turn it off.  
  
If using the optional manual folding seat, be sure to fasten the seat belt.
- 11 Lower the safety arm and the access ramp will lift up automatically (Figure 8 - bottom).
- 12 Insert the key into the platform key switch and turn it on to activate the platform controls.

**Figure 8**

- 13 To travel up or down the stairs:
  - Press either the **UP** or **DOWN** drive button on the pendant control (shown in Figure 9) to drive the lift to the desired landing. *Note that the safety arms remain down and the access ramps remain up in the locked position as long as the lift is in motion.*
  - The lift will stop automatically at all landings. If you keep the drive button pressed at an intermediate stop, the lift will stop briefly and then continue travelling towards the next landing.
  - If you need to stop the lift along the travel route for any reason, release the drive button. If this does not work, press the red emergency STOP button on the platform control panel or the handheld pendant.



**14** When the lift reaches the desired landing, it stops automatically.

**15** For lifts with a manual platform, release the drive button. Lift up the safety arm and the exit ramp will lower automatically (see Figure 10).

For lifts with an optional automatic platform, keep the drive button pressed until the safety arm is raised and the exit ramp is lowered.

**NOTE:** If there is an acoustic signal 5 seconds after releasing the drive button, then the lift is probably not in the exact recharging position. Reactivate the drive button to bring the lift to the exact position.

**16** Turn off and remove the key from the platform key switch.

**17** Disengage the wheelchair brakes and drive off the platform.

If the optional manual folding seat was used, release the seat belt.

**18** For lifts with a manual platform, lower the safety arms and fold up the platform and seat by hand.

For lifts with an optional automatic platform, press the **FOLD** button on the call station to fold down the safety arms and fold up the platform, and then fold up the seat by hand (see Figure 11).

**NOTE:** When you fold up the platform, the call station controls are reactivated so you can send the lift to the desired parking station if needed.

**19** When the lift is not in use, be sure to switch it off with the platform key and keep the key in a safe place to avoid unauthorized use.

**Figure 10**



**Figure 11**



## Manual Operation in an Emergency

You can use manual operation to bring the lift to the next landing in the event of a battery failure or equipment breakdown.



### WARNING

**Before proceeding with manual operation, you MUST switch off the main power switch.**

### Moving the Lift in an Emergency

- 1 Switch off the main power switch.
- 2 Remove the plug from the motor cover and insert the handwheel on the motor shaft (see Figure 12 below).
- 3 Tighten the brake lever to release the motor brake and turn the handwheel until the closest landing has been reached. This process is very slow.

**Figure 12**

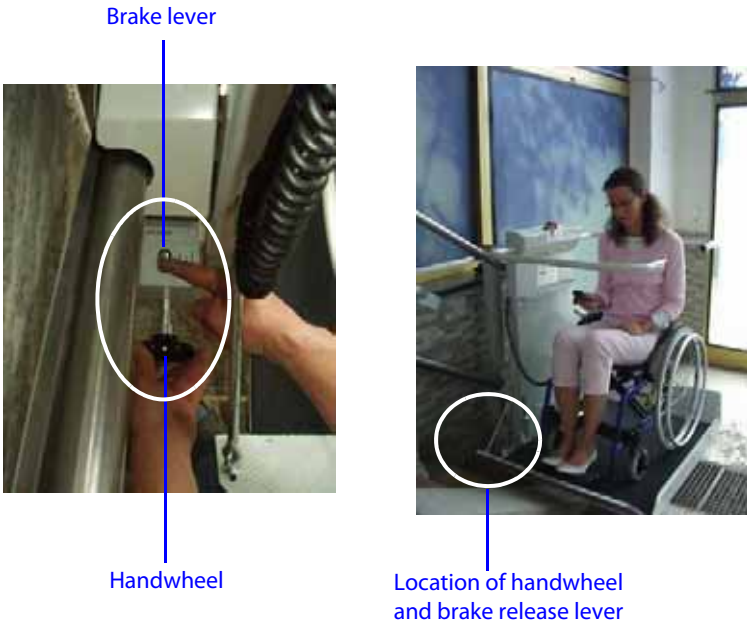



- 4 Lift up the safety arm and assist the passenger off the platform.  
**NOTE:** If you are unable to drive the lift to the next landing, you will need to release the safety arms as described in the procedure below.
- 5 If the lift has a manual platform, fold up the platform as the safety arms lower.
- 6 Lock the platform with the padlock on the carriage.
- 7 Remove the handwheel and store it in an easily accessible place.
- 8 Reinstall the plug in the motor cover.
- 9 Contact your authorized dealer if repair to the lift is required.

### NOTE

*After use of any emergency function (access key or manual lowering device), ensure that all doors/gates are secure and locked. While the emergency function is in use, DO NOT leave the area unattended.*

### Releasing the Safety Arms in an Emergency

- 1 To release a safety arm, press and hold the upper landing arm release lever located at the back of the carriage (see Figure 11 on the next page).
  - To release the left safety arm (as viewed from the front of the unit), press the upper lever.
  - To release the right safety arm (as viewed from the front of the unit), press the lower lever.
  - Note that this is the same for a left- or a right-hand unit.



### WARNING

**Be very careful not to release the downside safety arm and put the passenger in danger.**

- 2 While pressing and holding the appropriate lever, release the safety arm by pulling abruptly.

**Figure 13**

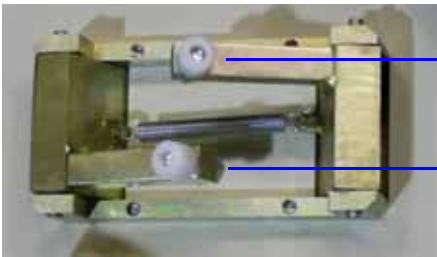
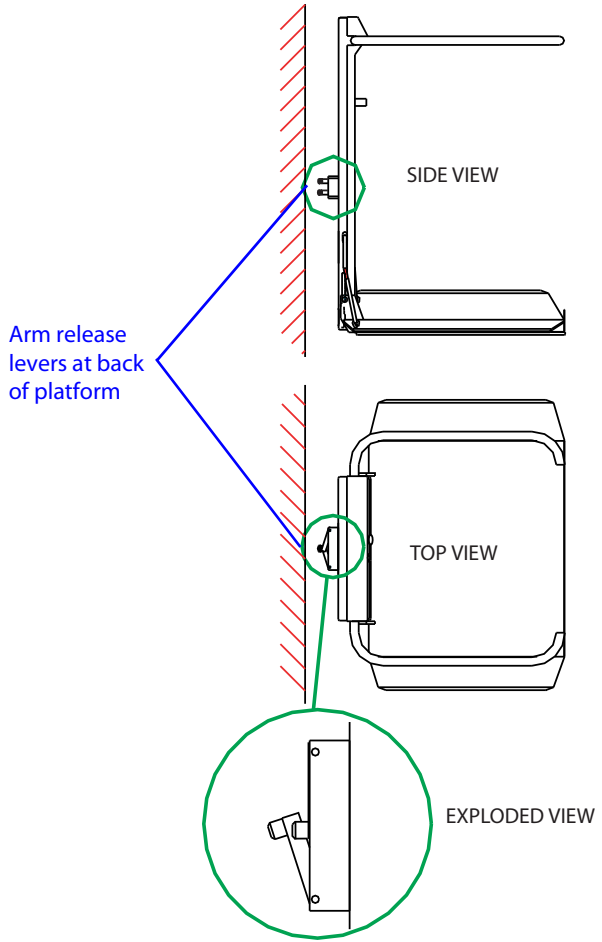

---

## 5. TROUBLESHOOTING

For safety reasons, the lift is equipped with several electrical and mechanical locking devices. The lift will not work if any of these devices is tripped or if the order of events is incorrect.



### WARNING

**Only qualified technicians are authorized to perform repairs and 6-month maintenance. DO NOT manipulate, modify or remove any safety feature of the lift. Contact your authorized dealer as necessary.**

Follow through the items below to determine a possible reason for the problem before contacting your authorized dealer.

- 1 If you're having a problem with a call station, note the following:
  - When the controls at one call station are activated, all other call stations are automatically deactivated. The lift can only be controlled by one control at a time.
  - The platform must be folded up for the call station controls to function.
  - Check that the key switch (if equipped) on the call station is turned on.
  - Check the batteries in the call station and replace if necessary.
- 2 If the lift is emitting an acoustic signal, check the lift batteries as described in the section, "Battery charging".
- 3 If the lift will not move, check the following:
  - Check that the main power switch on the lift is turned on. Turn on the platform key switch and make sure the green lamp on the platform turns on.
  - Check that there are no blown fuses in the building power distribution box.
  - Check that all emergency STOP buttons are released.
  - Check for obstacles underneath the access ramps and platform.

If the problem persists, contact your authorized dealer for assistance.

## Diagnostic LEDs

There are five LEDs located on the left-hand side of the platform control panel (see below).

**Figure 14**



### LED Status

<b>3 LED Panel</b>	<b>Meaning</b>
Middle and right LEDs on	Left-hand obstruction (or ready to run right)
Middle and left LEDs on	Right-hand obstruction (or ready to run left)
Middle LED on	Obstruction, both right-hand and left-hand
All 3 LEDs off	Safety circuit fault
All 3 LEDs on	Ready to run left or right
<b>2 LED Panel</b>	<b>Meaning</b>
Platform folded LED on	Platform is folded up
Platform unfolded LED on	Platform is unfolded

## 6. MAINTENANCE

Periodic checks and maintenance are necessary to ensure your safety and proper operation of the lift. Refer to the table below for a list of checks and maintenance items.



**To ensure your safety and proper operation of the lift, be sure to check the items below that are identified as WEEKLY. Contact your authorized dealer to perform 6-month maintenance and repairs.**

MAINTENANCE SCHEDULE	
ITEM TO BE CHECKED	FREQUENCY
<b>BY OPERATOR</b>	
Check that the lift does not start moving until the safety arms are down and the access ramps are up in the safety position.	Monthly
Check that the safety arms and ramps remain closed while travelling.	Monthly
Verify that the safety arms cannot be lifted up when you are travelling between two landings.	Monthly
Verify that the lift stops immediately when the emergency STOP button is pressed.	Monthly
Verify that the lift stops at every landing.	Monthly
Verify that the lift stops when the directional drive button is released.	Monthly
Verify that the lift stops immediately if the ramp runs into an obstacle.	Monthly
Verify that the lift stops immediately if an obstacle is detected underneath the platform.	Monthly
Use a dry clean cloth to clean the outside of the rail tubes.	As required
Ensure clear access to the drive and main power switch.	As required

<b>BY AUTHORIZED DEALER</b>	
Verify proper operation of all limit switches.	Every 6 months
Check that the electromagnetic brake on the motor stops the lift when fully loaded before the final limit switch is tripped. If necessary, adjust or replace the brake.	Every 6 months
Check that the drive sprocket teeth and the nylon rollers on which the lift runs are not worn or damaged. There must be no scoring or flattening of the rollers.	Every 6 months
Verify proper operation of the safety brake (overspeed governor).	Every 6 months
Check that all fixing screws on the rails and carriage are present and securely fastened.	Every 6 months
Check all moving parts, covers, signs, and labels.	Every 6 months
Clean the rail thoroughly.	Every 6 months
Verify proper operation of the pendant control buttons.	Every 6 months
Verify proper operation of the call station control buttons.	Every 6 months
Check that all electrical components, contactors and microswitches are operating correctly. Check the condition of all cables. Check the grounding.	Every 6 months
Check condition of battery and charger.	Every 6 months

**NOTE**

*Units installed in adverse environments will require additional maintenance on a monthly basis.*



**Authorized Savaria Dealer**

# **DELTA**

## **Straight Inclined Platform Lift**

### **OWNER'S MANUAL**

Part No. 000820  
© Copyright 2020

Savaria Concord Lifts, Inc.  
2 Walker Drive  
Brampton, Ontario, L6T 5E1, Canada  
[www.savaria.com](http://www.savaria.com)

For service or questions about this product, please contact your installing dealer.

DEALER NAME: \_\_\_\_\_

DEALER PHONE: \_\_\_\_\_

